

ACE

Reach Truck



Capacity : 1.2 T- 2.0 T

High Performance & rugged
Reach Truck

ACE INDIA'S NO. 1
CRANE BRAND



| | Description | Unit | Technical Specifications | | | | | |
|-----------------------|--------------------------|------------------------------------|--------------------------|-----------------|-----------|------|-----------|--|
| | | | RT12 | RT14 | RT16 | RT20 | | |
| General | 1 | Manufacture | ACE | | | | | |
| | 2 | Model | | | | | | |
| | 3 | Power Type | Battery | | | | | |
| | 4 | Rated Capacity | Kg | 1200 | 1400 | 1600 | 2000 | |
| | 5 | Load Center | mm | 600 | | | | |
| Dimensions | 6 | Lift Height | mm | 3000 | | | | |
| | 7 | Free Lift | | 340 | | | | |
| | 8 | Fork Size L x W x T | mm | 1070 x 122 x 40 | | | | |
| | 9 | Fork Spread (out side) Min./ Max. | mm | 244 / 882 | | | | |
| | 10 | Mast Tilt Range (Forward/Backward) | deg | 2/4 | | | | |
| | 11 | Axle Centre to Fork Face | mm | 308 | | 218 | 288 | |
| | 12 | Overall Dimensions | Length to Face of Fork | mm | 1935 | | 2005 | |
| | 13 | | Overall Width | mm | 1270 | | 1286 | |
| | 14 | | Mast Lowered Height | mm | 2100 | | | |
| | 15 | | Mast Extended Height | mm | 3565 | | | |
| | 16 | | Overhead Guard Height | mm | 2200 | | | |
| 17 | Turning Radius (Outside) | mm | 1735 | | | 1804 | | |
| 18 | Aisle Width for pallets | 1000 x 1200 crossways | mm | 2855 | 2921 | 2935 | | |
| 19 | | 800 x 1200 Lengthways | mm | 2915 | 2995 | 3000 | | |
| Performance | 20 | Speed | Travel | Km/h | 10.3 | | | |
| | 21 | | Lifting (Full Load) | mm/sec | 280 | 280 | 280 | |
| | 22 | Reach Distance | mm | 525 | 435 | 505 | | |
| | 23 | Max.Gradeability (Full Load) | % | 10 | | | | |
| 24 | Self Weight | Kg | 3110 | 3300 | 3320 | | | |
| Wheels & Tires | 25 | Wheels (diameterxwidth) | Front | mm | 285 x100 | | 343 x 108 | |
| | 26 | | Drive | mm | 343 x 114 | | | |
| | 27 | Wheelbase | mm | 1480 | | | 1550 | |
| | 28 | Ground Clearance (Minimum) | mm | 70 | | | | |
| Drive Units & Control | 29 | Battery | Model | | D - 400B | | D - 500B | |
| | 30 | | Voltage /Capacity(5HR) | V/AH | 48 / 400 | | 48 / 500 | |
| | 31 | | Weight (With Box) | Kg | 760 | | 900 | |
| | 32 | Electric Motors | Drive | Kw | 6.5 | | | |
| | 33 | | Load | Kw | 12.8 | | 14.5 | |
| | 34 | | Steering | Kw | 0.67 | | | |
| | 35 | Control | Manufacture | | CURTIS | | | |
| | 36 | | Type | | AC | | | |

LOAD CHART

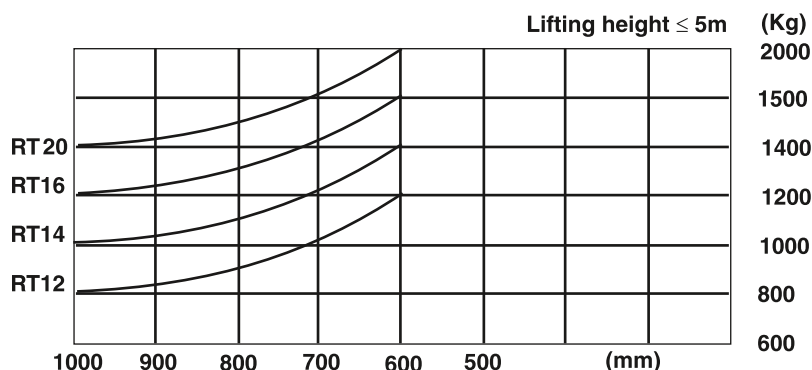

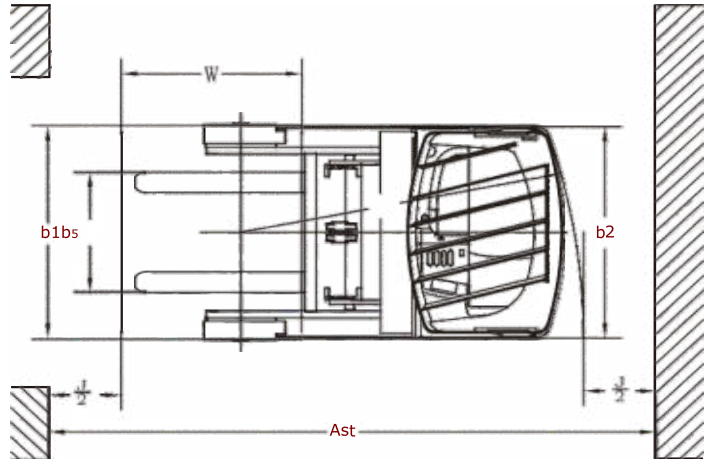
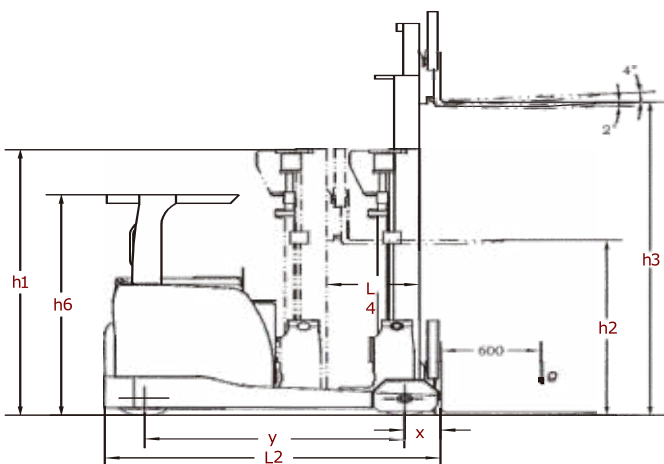

| Max Fork Height(mm) | Load Capacity @ 600mm MFH (KGS) | | | | Mast Lowered Height (mm) | Mast Extended Height(mm) | Free Lift Height (mm) | |
|---------------------|---------------------------------|------|------|------|--------------------------|--------------------------|-----------------------|-------|
| | RT12 | RT14 | RT16 | RT20 | | | 1.2T - 1.6 T | 2.0 T |
| 4500 | 1200 | 1400 | 1600 | 2000 | 2165 | 5230 | 1445 | 1445 |
| 6000 | 1200 | 1200 | 1400 | 1800 | 2665 | 6730 | 1945 | 1945 |
| 6500 | 1100 | 1100 | 1300 | 1700 | 2815 | 7230 | 2095 | 2095 |
| 7000 | 1000 | 1000 | 1200 | 1600 | 2975 | 7730 | 2255 | 2255 |
| 7500 | 1000 | 1000 | 1200 | 1600 | 3230 | 8190 | 2540 | 2540 |
| 8000 | 900 | 900 | 1100 | 1500 | 3400 | 8670 | 2730 | 2730 |
| 8500 | 800 | 800 | 1000 | 1400 | 3630 | 9170 | 2960 | 2960 |
| 9000 | 700 | 700 | 900 | 1300 | 3860 | 9670 | 3186 | 3186 |
| 9500 | - | - | 850 | 1200 | 4030 | 10170 | 3360 | 3360 |
| 10000 | - | - | 800 | 1150 | 4200 | 10680 | 3520 | 3520 |
| 10500 | - | - | 700 | 1100 | 4350 | 11170 | 3680 | 3680 |
| 11000 | - | - | - | 1050 | 4550 | 11670 | 3880 | 3880 |
| 11500 | - | - | - | 1000 | 4800 | 12200 | 4100 | 4100 |
| 12000 | - | - | - | 900 | 5050 | 12690 | - | 4360 |
| 12500 | - | - | - | 800 | 5300 | 13200 | - | 4600 |

Features :-

- **AC Motors** For Top Drive & Lift Performance.
- **Electronic Fork Control** Cushioning effect enables high lift / lowering speed but smooth operation.
- **Panoramic View** Excellent all-Around Visibility for Ease to Working.
- **Well Placed Control** Ensure comfort of operation.
- **Service & Maintenance** All major service components like Motors, Gearbox Brakes, Pump and Steering are easily accessible.

Standard Features :-

- PU(polyurethane) driving wheel and load wheels
- High-capacity battery
- Emergency power off switch
- 4 spools control valves
- Stepless speed regulation for lifting operation
- Electrical buffer for forward and backward movements
- Arm cushion, and impact-proof head cushion
- Adjustable seat with OPS switch
- Full computer control for driving, steering
- Standard configuration of 360-degree steering mode
- Adjustable steering wheel
- Front wheel protection hood
- Safety pedal
- Descending self-locking in case of power failure

Optional Features :-

- 2.7-5.0m duplex mast, built-in-side shifter, fork tilting
- 4.3m-12.5m full-free triplex mast built-in-side shifter, fork tilting
- Various fork lengths
- High-performance battery
- Optional large capacity battery 420Ah, 560Ah
- Full automatic high-frequency charger
- Other attachments
- Larger load backrest
- Height monitoring system
- Lifting height limitation system
- Alarm lamp, rear headlamp or other lamps
- Reverse buzzer
- Camera & Height Indicator



BUILT TO PERFORM



**RELIABLE AND
DEPENDABLE
EFFICIENCY**

NETWORK

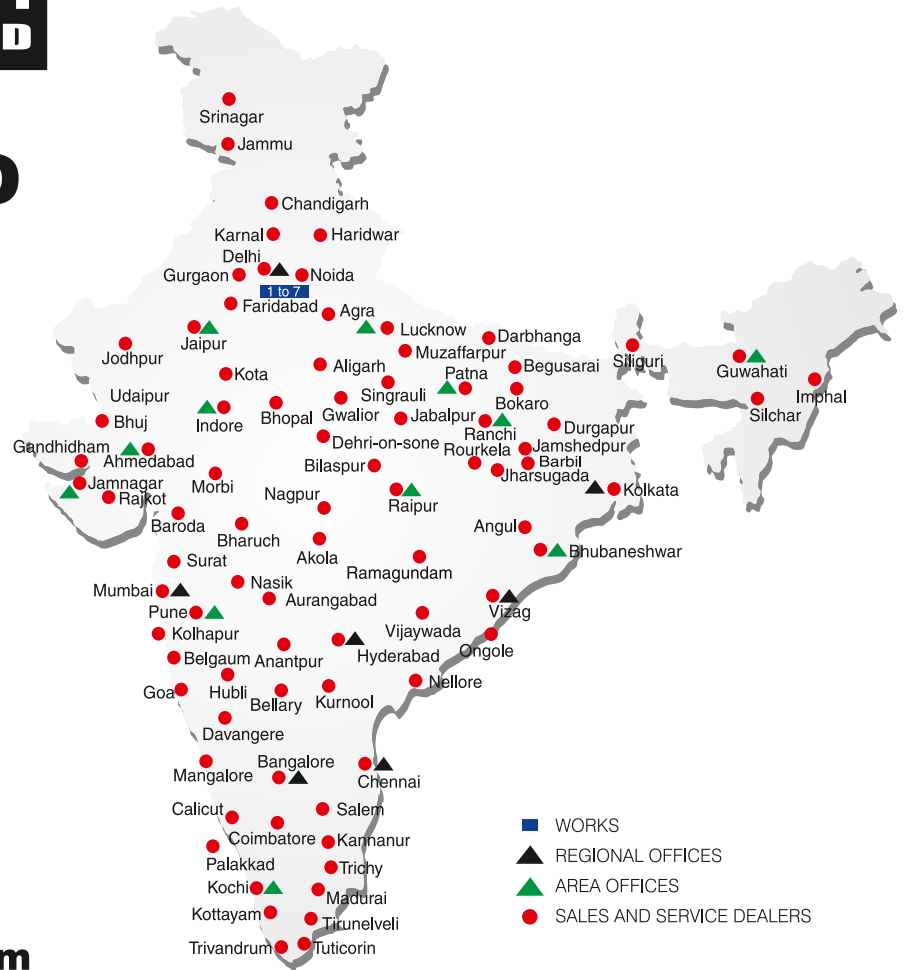

www.ace-cranes.com

MARKETING H.Q.

4th Floor, Pinnacle
Surajkund, NCR-121009
Ph. : +91-129-4550000
Fax : +91-129-4550022
E-mail: marketing@ace-cranes.com

REGISTERED OFFICE

Dudhola Link Road, Dudhola
Palwal-121102, Haryana
Ph.: +91-1275-280111
Fax: +91-1275-280133
CIN : L74899HR1995PLC053860

MUMBAI OFFICE

31, "Kalpataru Court"
Chembur, Mumbai - 400074
Ph.: +91-22-25206846, 25207070
Fax: +91-22-25207071
E-mail: acemumbai@ace-cranes.com

KOLKATA OFFICE

"Forma Towers" 84-A, Second Floor
AJC Bose Road, Kolkata - 700014
Ph.: +91-9038070630
E-mail: acekolkata@ace-cranes.com

CHENNAI OFFICE

1st Floor, "Alsa Regency", 165
Eldams Road, Alwar Pet
Chennai - 600018
Ph.: +91-44-24314253
Fax: +91-44-24314252
E-mail: acechennai@ace-cranes.com

HERE TO SERVE YOU.

SPARE PARTS & SERVICE

ACE has all India Sales and Service network operating out of all the major cities. These outlets are fully equipped to provide genuine spare parts and services by company trained engineers. These outlets are further supported by company officials based at Delhi, Mumbai, Chennai, Kolkatta, Ahmedabad, Surat, Pune, Jaipur, Chandigarh, Ranchi, Raipur, Indore, Bhubneshwar, Lucknow, Jamnagar, Hyderabad, Bangalore, Guwahati, Patna, Vizag & Kochi.



Action Construction Equipment Ltd.

Contact:



ACE reserves the right to alter any specifications without prior notice. Dimensions, weights & capacities mentioned herein are variable by ± 5%. Accessories if shown are not part of the Standard Equipment.